

Model **FP14KO-A**

Wheel alignment & Open Front
Four-Post Lift

(**14000LBS / 6300Kg Capacity**)

ASSEMBLY & OPERATION

INSTRUCTIONS

(Series T1)



2009.7.

INTRODUCTION

Model FP14KO-A is a four-post lift is used in wheel alignment, vehicle inspection and maintenance for various types of cars and light trucks.

Features:

- Open front end for easy access car servicing
- Multi-position cut-out for turntables (optional part) and extra long rear slip plates to accommodate a wide range of vehicles.
- Over load safety release valve in pump and hydraulic system.
- Pneumatic lock release system and redundant cable failure safety device.
- Built in rails for rolling jacks.

SPECIFICATIONS

CAPACITY:	14000 LBS / 6300Kg		
MOTOR POWER:	220V, single phase, 2.2 Kw, 10 A		
HYDRAULIC PUMP OIL:	10-WT hydraulic oil or DEXRON-III ATF fluid.		
WORKING TEMPERATURE:	5 – 40 °C		
NOISE:	≤ 76 db		
OVERALL LENGTH:	294" (7403mm)	OVERALL WIDTH:	139" (3530mm)
PLATFORM LENGTH:	243 1/4" (6178mm)	PLATFORM WIDTH:	19" (510 mm)
MAX PLATFORM HEIGHT:	72 7/8"(1850mm)	MIN PLATFORM HEIGHT:	8 1/4"(211mm)
LIFTING TIME (AVERAGE):	50 sec	LOWERING TIME (MAX):	60 sec

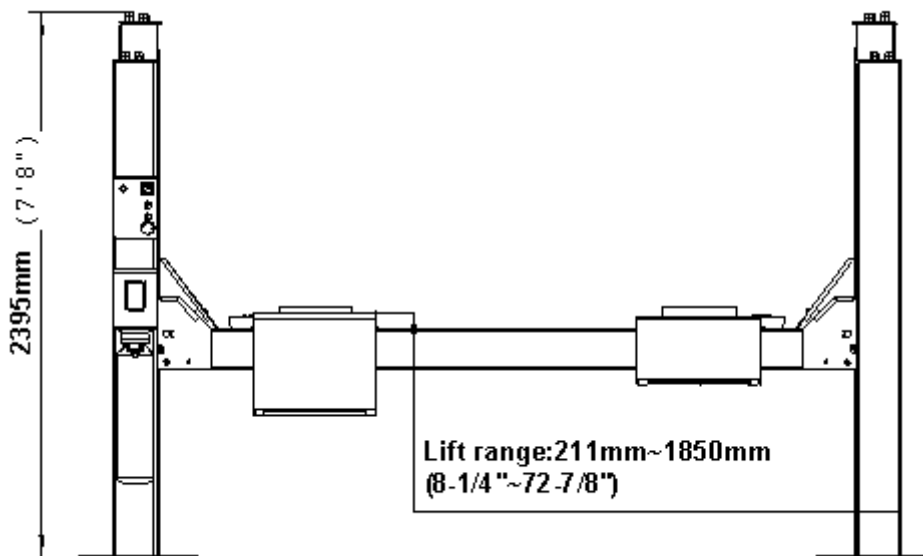

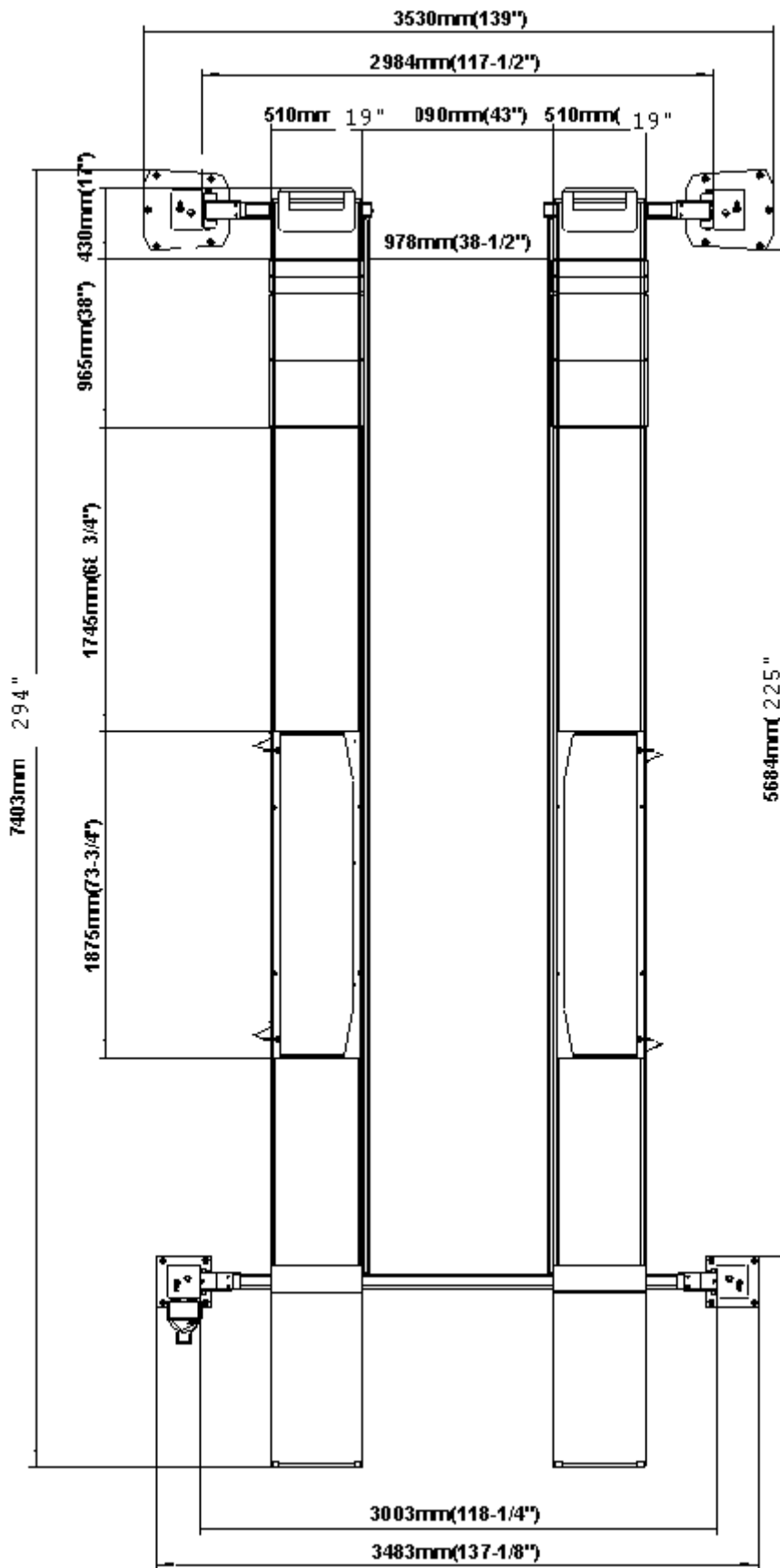

Note: All dimensions typical

Fig. 1

TOOLS REQUIRED IN INSTALLATION

Rotary hammer drill or similar

3/4" Masonry bit

Hammer

4 foot level

Open-end wrench set : 7/16" – 1-1/8"

Socket and ratchet set: 7/16" – 1-1/8"

Hex-key / Allen wrench set

Medium crescent wrench

Medium pipe wrench

Crow bar

Chalk line

Medium flat screwdriver

Tape measure: 25 foot minimum

Needle nose pliers

Fork lift

INSTALLATION

IMPORTANT NOTICE

These instructions must be followed to insure proper installation and operation of your lift. Failure to comply with these instructions can result in serious bodily harm and void product warranty. Manufacturer will assume no liability for loss or damage of any kind, expressed or implied resulting from improper installation or use of this product.

PLEASE READ ENTIRE INSTRUCTION BEFORE STARTING TO ASSEMBLE THE LIFT

STEP 1: (Selecting Site) Before installing your new lift, check the following:

1. **LIFT LOCATION:** Always use architects plans when available. Check layout dimension against floor plan requirements making sure that adequate space is available (See FIG. 2). The specified safety distances must be from front wall 63 inch (1600mm) , from side wall 39 1/2 inch (1000 mm) at least. The room ceiling must be at least 157 1/2 inch (4000mm) in height.

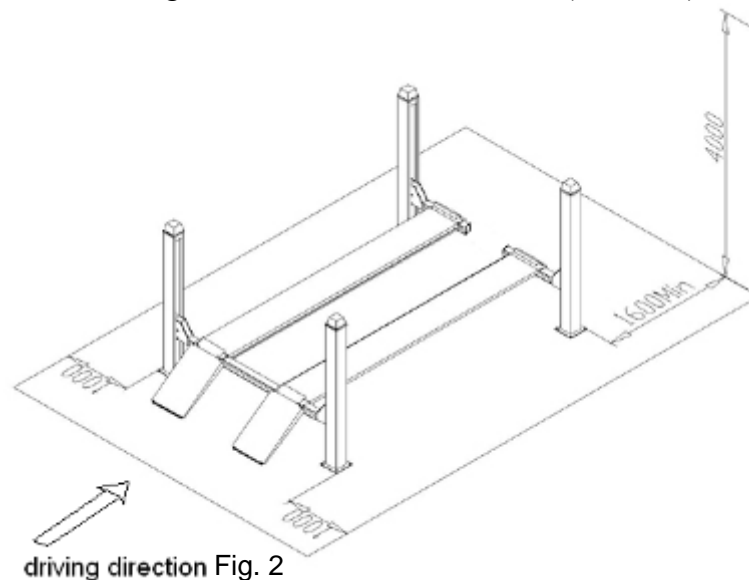

2. **FLOOR REQUIREMENTS:** The lift should be installed on a 3000 PSI concrete with little gradients. Thickness of concrete ≥ 6 inch (150 mm). The leveling of whole area $\leq 3/8$ inch (10 mm). Or, every column shall be located on a concrete block with size at least 24*24 inch (600*600 mm), thickness ≥ 8 inch (200mm)

STEP 2: (Unloading and Unpacking)

1. After unloading the lift, place it near the intended installation location.
2. Remove the shipping bands and packing materials from the unit.
3. Remove the packing brackets and bolts holding the two columns together. (Do not discard bolts, they may be used in the assembly of the lift)

STEP 3: (Site Layout)

1. Once a location is determined, use a carpenters chalk line to layout a grid for the platform locations. (See Fig.1). Keep all dimensions square and within 1/8" otherwise a malfunction of the lift will occur.
2. Before continuing with the installation it is helpful to get a visual look of the shop, and other clearances. Also, this is a good time to drive a vehicle into the position and check for adequate clearance.

- Note: All 4 legs should be level and square. Use the layout dimensions for floor layout purposes only

NOTE
 All models **MUST** be installed on 3000PSI concrete only confirming to the minimum requirements. New concrete must be adequately cured by at least 28 days minimum.

STEP 4: (Locate the parts)

- Use fork lift to move the platforms in the desired position. Use a wooden block or safety stand under the platforms to set them about 12” (300mm) off the ground and parallel to each other.
- Put the cross beams and columns near their positions.

STEP 5: (rear crossbeam)

- Take off the cable sheave by unlocking the screws and pins on both ends of the cross beam
- Attach the rear crossbeam to the left (main) platform with cylinder and cables.
- Line the cables through the hole on the crossbeam out from the end. Be sure the cables are in the proper sheave grooves. (Fig .3 & parts drawing-2)

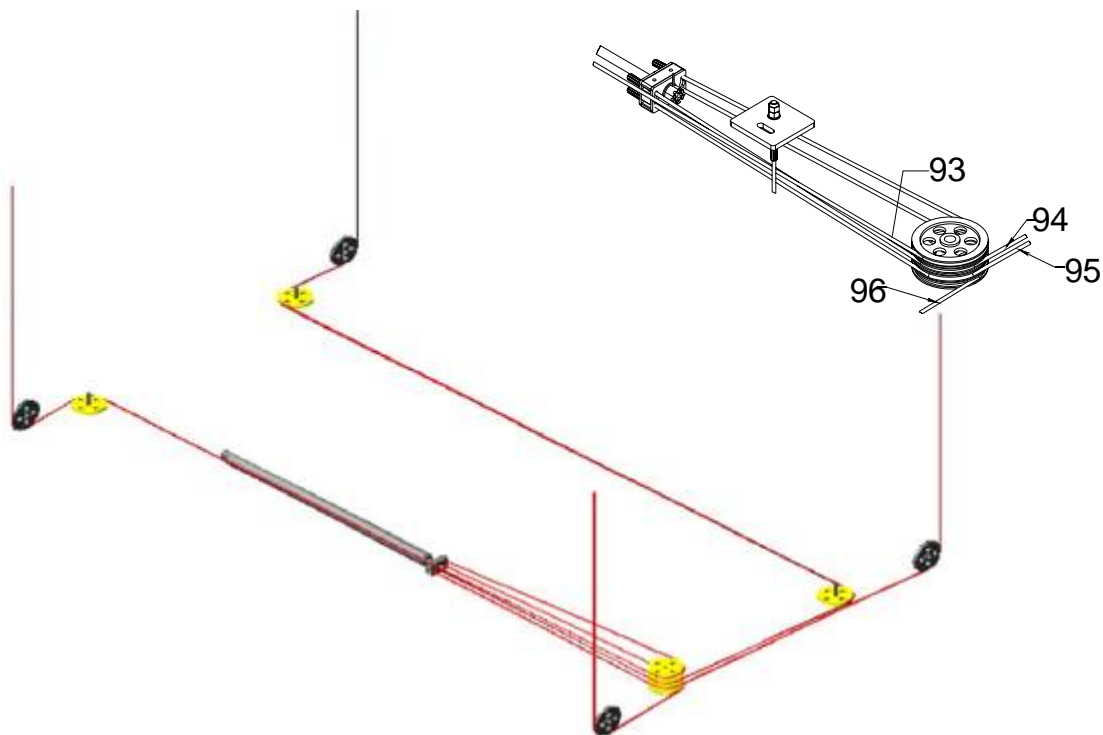

Fig. 3

- Take off the two cable sheaves also on the ends of sub platform. Line the longest cable through the sub platform.
- Connect the cross beam with the platforms by bolts.
- Put back all the cable sheaves on cross beam and sub platform.
- Move the rear columns to the cross beam. Unlock the nuts on the top of the column to pull up the safety rack above the cross beam then insert it through the cross beam end. Make sure the safety lock can rest on the rack. (Fig 4)
- Line the cable up to the top of the column. Make sure the slack cable lock is pushed by the cable. Tighten up the nut on the cable end and rack end.(Fig. 5)

9. Mount on the plastic slide blocks on the crossbeam.(Fig. 6)
10. Fix the lower end of the safety rack by a bolt. (Fig 7)

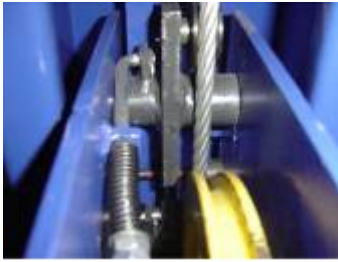

Fig 4



Fig. 5



Fig. 6



Fig. 7

STEP 6: (front yoke)

1. Lay down the front columns. Take out the safety rack.
2. Take off the cable sheaves of the front yokes.
3. Slide the front yoke into its column (open hole towards the platform)
4. Insert the safety rack through the yoke same as the rear cross beam.
5. Set up the front columns. Move them to the front end of the platforms.
6. Raise up the front yoke to touch the platform then rest on the safety rack. (At least one man to take care of the column. It is unstable at this step)
7. Line the cable through the yoke and column.
8. Bolt the yoke with the platform.
9. Fix the bolt on the lower end of the safety rack.
10. Do the same with another front yoke.

STEP 7: (anchor the front columns)

1. Check carefully with the location of the columns and its plumb. Using a tape measure to measure the distance between the opposite corners of the base plate on the columns. Equal values will insure the lifting arms will be in square.
2. Using the base plate on the front column as a guide, drill an anchor hole on the back of the column in the concrete approximately $5\frac{1}{2}$ " deep using a rotary hammer drill and $\frac{3}{4}$ " concrete drill-bit. To assure full holding power, do not ream the hole or allow the drill to wobble.
3. Anchor the front column for safety.

STEP 8: (hydraulic system)

1. Mount on the motor pump on the column with bracket. (Fig. 8)
2. Also mount the air-release valve bracket with the pump (Fig. 9)
3. Connect the hose from pump to cylinder with the connector supplied.
4. Fill the tank with hydraulic oil (about 10 liters)
5. Have a certified electrician to run the 220V/60Hz single phase power supply to the motor. Be sure to size the wire for a 25 amp circuit.
6. Mount on the air-release valve. Connect the compressed air supply through pipe supplied.



Fig. 8

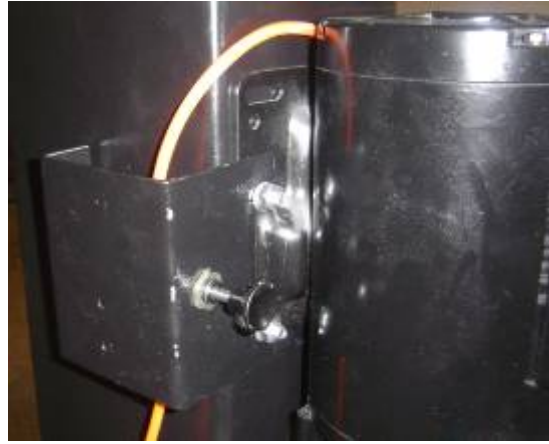

Fig. 9

STEP 9: (check again)

1. Raise the platform a little by pushing the up button on the power unit.
2. Check the location of all the columns again. Make sure everything is OK.
3. Again using the base plate of the column as guide, drill all the holes for anchoring.
4. Anchor all the columns using bolts supplied. Make plumb by placing shims as close as possible to the anchor bolts. This will prevent bending the column base plates.
5. Check that all the cables are in sheave grooves.
6. Check the leveling of the platforms. Adjust the length of the cables by the nuts on cables end to level the platforms.
7. Lower the platforms by simultaneously pressing the air-release valve and the release lever on the power unit.
8. If the platforms not level, adjust the height of the safety rack by the nut on the top of the column. Do not forget to tighten the bolt on the lower end of the rack.
9. Put on all the accessories such as front stop, ramp, cover etc.

STEP 10: (start up)

1. Do not place any vehicle on the lift at this time!
2. Cycle the lift up and down several times to insure lock latches click together and all air is removed from the system.
3. To lower the lift, the air- releases valve must be manually pressed while the lowering handle of the pump is pressed. Latches will automatically reset once the lift ascends approximately 17" " from base.

OPERATION

RAISE-LIFT

1. Press button on power unit

The latch mechanism will 'trip over' when the lift raises and drop into each latch stop. But, to lock the lift you must press the lowering handle to relieve the hydraulic pressure and let the latch set tight in a lock position.

Always lock the lift before going under the vehicle. Never allow anyone to go under the lift when raising or lowering. Read the safety procedures in the manual.

LOWER LIFT

1. Raise the lift until the latch clears. Approx. 2"

2. Push air valve for latch release while pressing the lowering handle on the power unit.

Note: It is normal for an empty lift to lower slowly-it may be necessary to add weight.

SAFETY PROCEDURES

- Never allow unauthorized persons to operate lift. Thoroughly train new employees in the operation and care of lift.
- Caution: the power unit operates at high pressure.
- Never permit passengers to ride in the vehicle.
- Prohibit unauthorized persons from being in shop area while lift is in use.
- Never exceed total lift capacity of 14000-lbs.
- Prior to lifting vehicle, walk around the lift and check for any objects that might interfere with the operation of lift and safety latches; tools, air hoses, shop equipment.
- When approaching the lift with a vehicle, center the vehicle wheel on the runway. Slowly drive the vehicle up on the runways. Have some one outside the vehicle guide the driver.
- Never use lift to raise one end or one side of vehicle.
- Prior to lowering vehicle, walk around the lift and check for any objects that might interfere with the operation of lift and safety latches; tools, air hoses, shop equipment. Slowly drive the vehicle out. Have some one outside the vehicle guide the driver.

ALWAYS LOCK THE LIFT BEFORE GOING UNDER THE VEHICLE. NEVER ALLOW ANYONE TO GO UNDER THE LIFT WHEN RAISING OR LOWERING.

MAINTENANCE SCHEDULE

The following periodic maintenance is the suggested minimum requirements and minimum intervals; accumulated hours or monthly period, which ever comes sooner. If you hear a noise or see any indication of impending failure - **cease operation immediately** – inspect, correct and / or replace parts as required.

WARNING: OSHA REQUIRES USERS TO INSPECT LIFTING EQUIPMENT AT THE START OF EVERY SHIFT. THESE AND OTHER PERIODIC INSPECTIONS ARE THE RESPONSIBILITY OF THE USER.

DAILY PRE-OPERATION CHECK (8 HOURS)

The user should perform daily check. ATTENTION! LOOK OUT! Daily check of safety latch system is very important-the discovery of device failure before needed could save you from expensive property damage, lost production time, serious personal injury and even death.

- Check safety lock audibly and visually while in operation
- Check safety latches for free movement and full engagement with rack.
- Check hydraulic connections, and hoses for leakage.
- Check cables connections- bends, cracks-and looseness
- Check for frayed cables in both raised and lowered position.
- Check snap rings at all rollers and sheaves.
- Check bolts, nut, and screws and tighten.
- Check wiring & switches for damage.
- Keep bass plate free of dirt, grease or any other corrosive substances.
- Check floor for stress cracks near anchor bolts.

WEEKLY MAINTENANCE (40 HOURS)

- Check anchor bolts torque to 150 ft/lbs. for the ¾" anchor bolts. Do not use impact wrench.
- Check floor for stress cracks near anchor bolts
- Check hydraulic oil level.
- Check and tighten bolts and nuts, and screws.
- Check cylinder pulley assembly for free movement or excessive ware on cylinder yoke or pulley pin.
- Check cable pulley for free movement and excessive ware.

YEARLY MAINTENANCE

- Lubricate cable sheaves.
- Grease rub blocks and column surface contacting rub blocks
- Change the hydraulic fluid- good maintenance procedure makes it mandatory to keep hydraulic fluid clean. No hard fast rules can be established;-operating temperature, type of

service, contamination levels, filtration, and chemical composition of fluid should be considered. If operating in dusty environment shorter interval may be required.

The following items should only be performed by a trained maintenance expert.

- Replace hydraulic hoses
- Replace cables and rollers.
- Replace cables and sheaves.
- Replace or rebuild air and hydraulic cylinders as required.
- Replace or rebuild pumps / motors as required.
- Check hydraulic and air cylinder rod and rod end (threads) for deformation or damage.
- Check cylinder mount for looseness and damage.

Relocating or changing components may cause problems. Each component in the system must be compatible; an undersized or restricted line will cause a drop in pressure. All valve, pump, and hose connections should be sealed and/ or capped until just prior to use air hoses can be used to clean fittings and other components. However, the air supply must be filtered and dry to prevent contamination. most important- cleanliness- contamination is the most frequent cause of malfunction or hydraulic equipment.

PARTS DRAWING-1

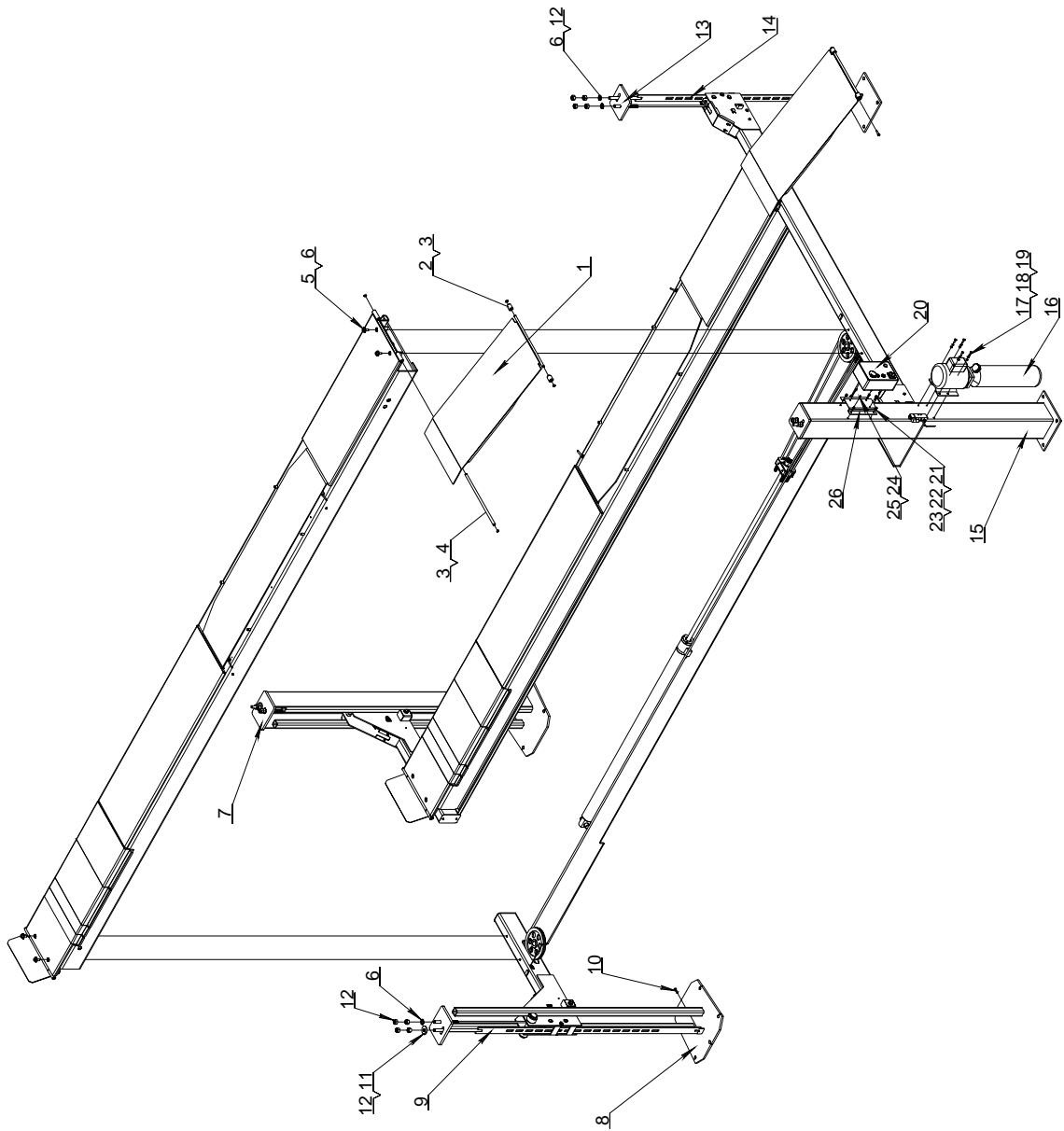

PARTS DRAWING-2

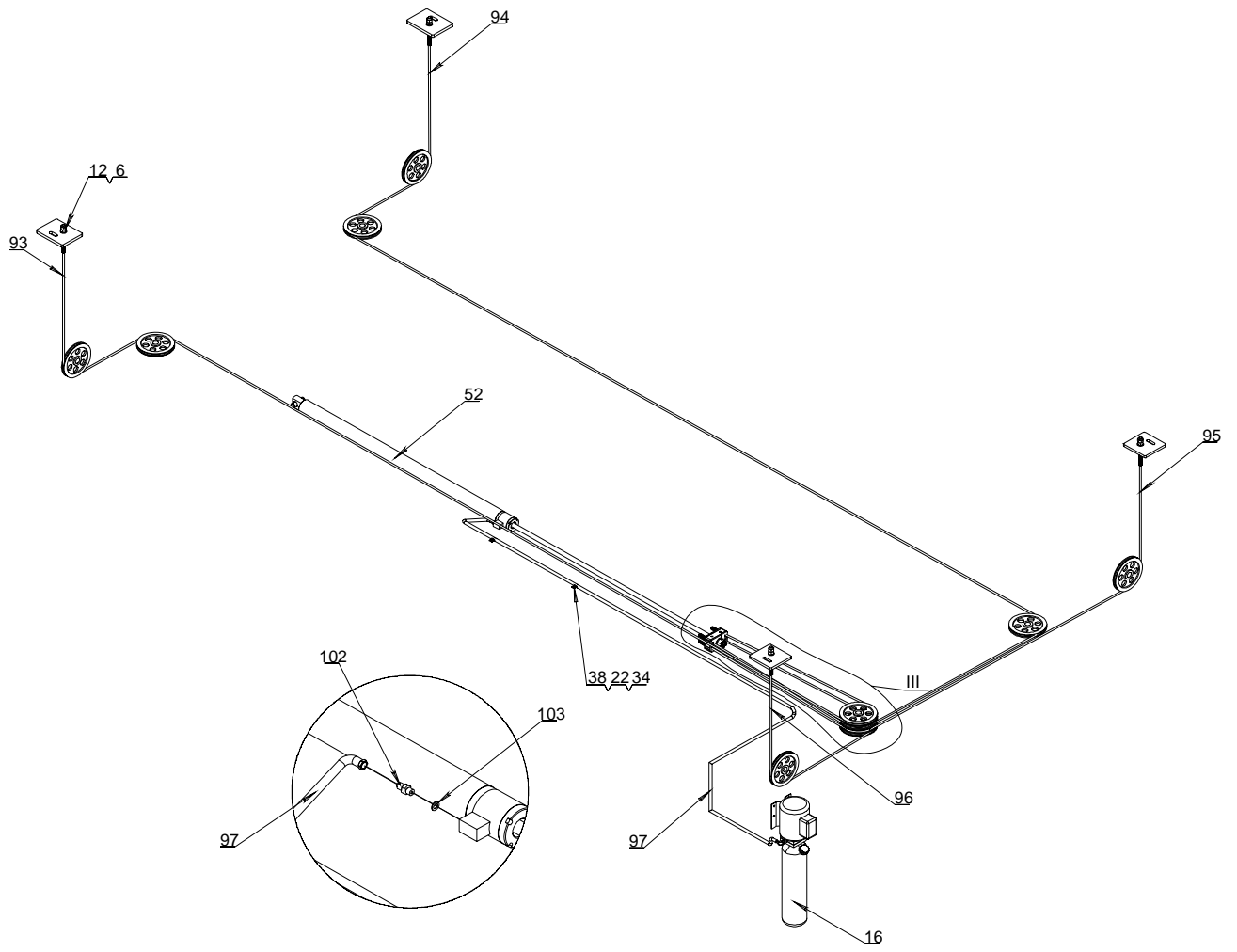

PARTS DRAWING-3

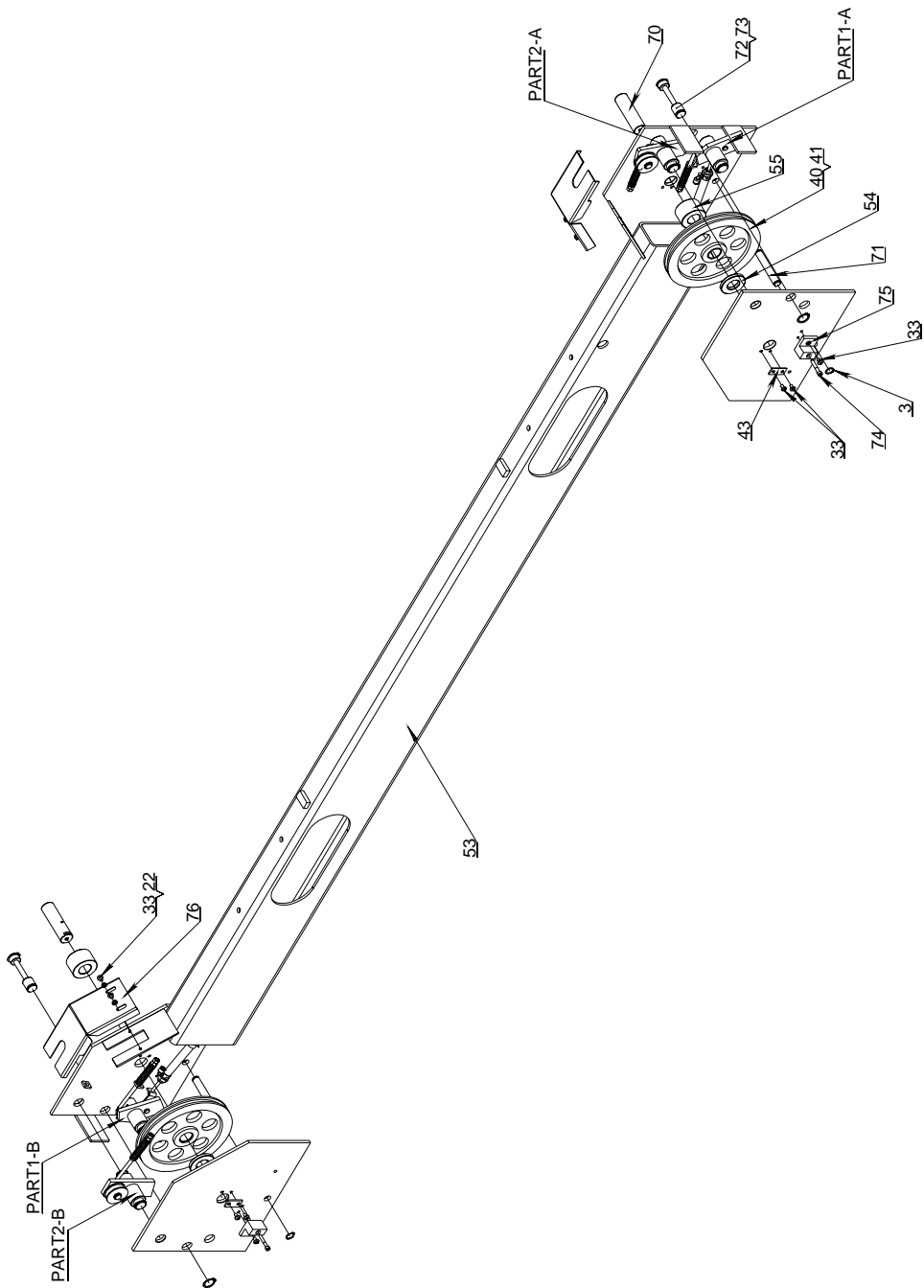

PARTS DRAWING-4

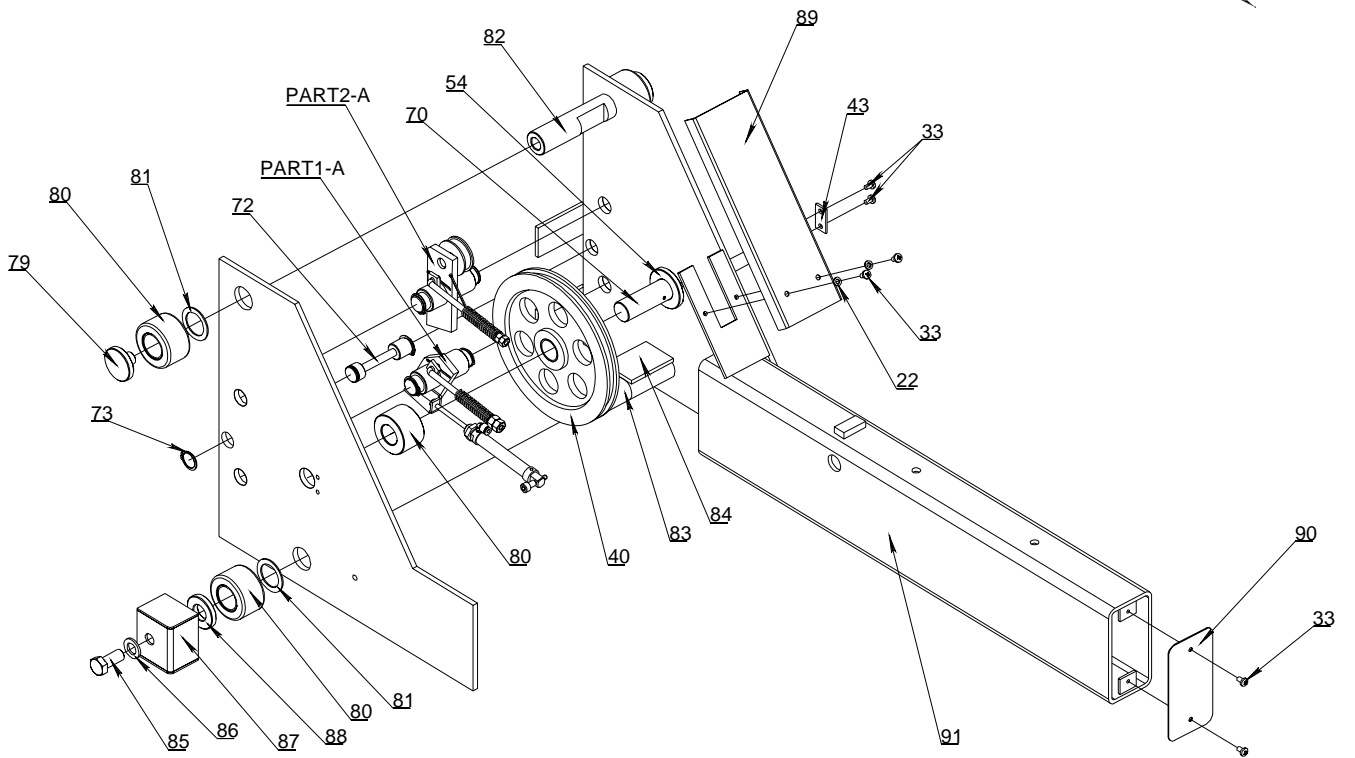
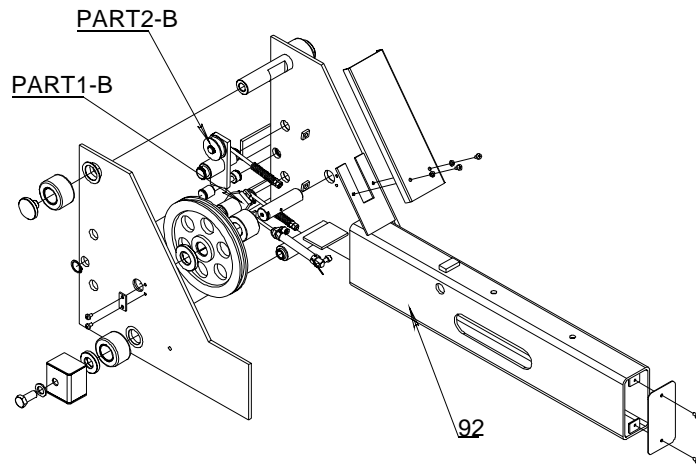

PARTS DRAWING-5

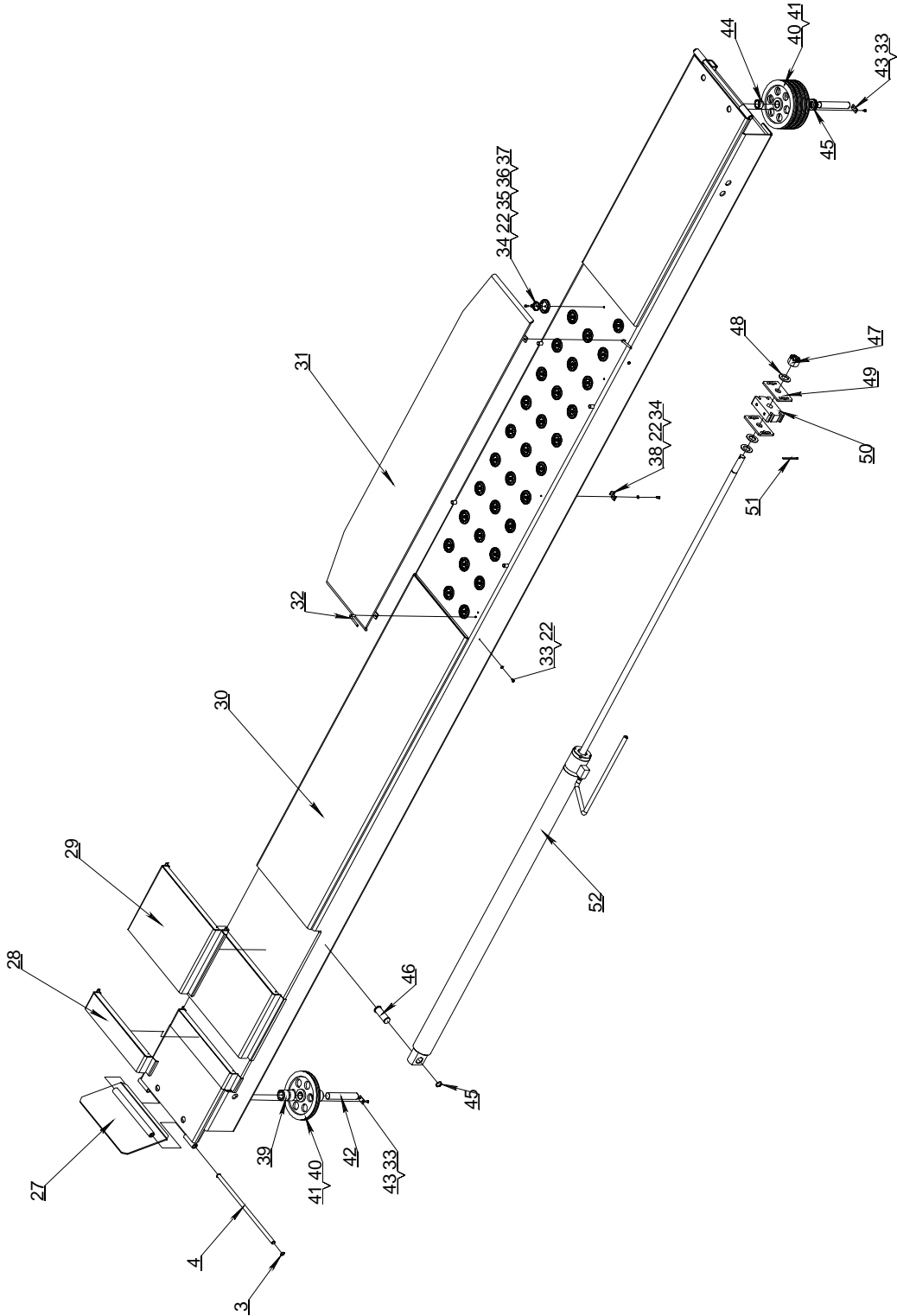

PARTS DRAWING-6

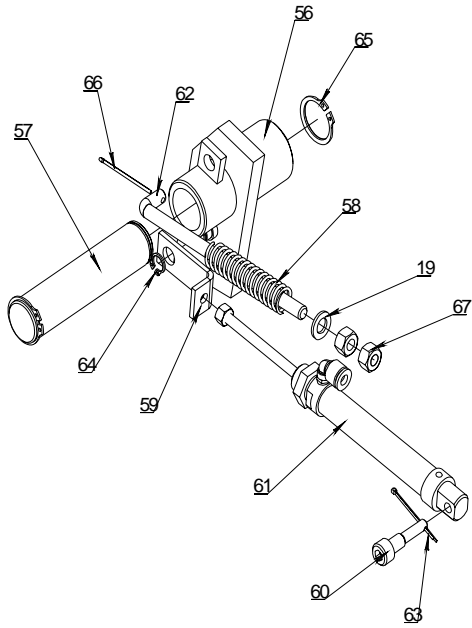

PART1-A

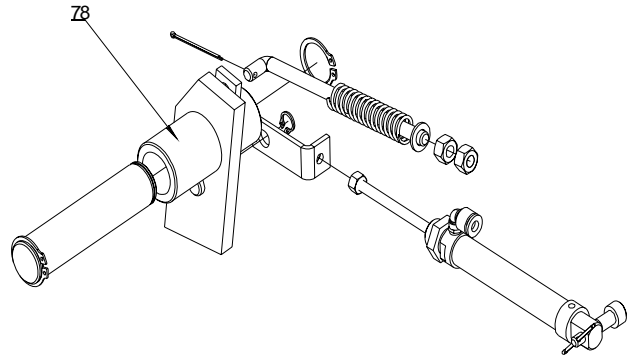

PART1-B

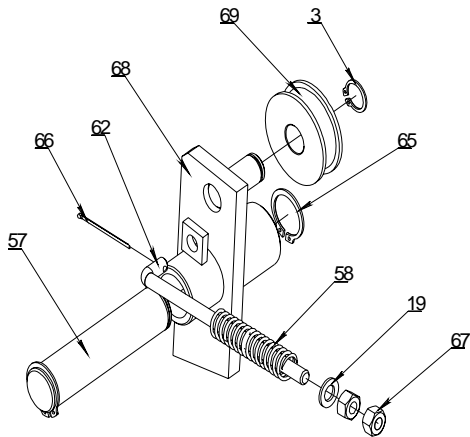

PART2-A

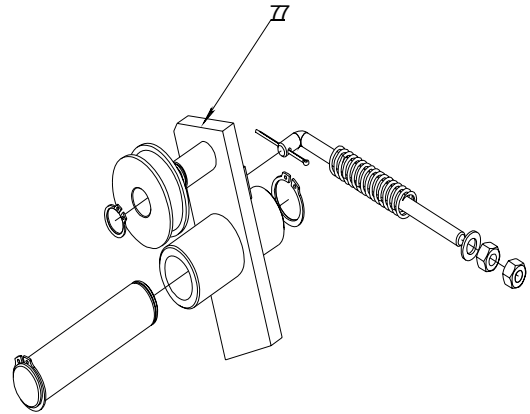

PART2-B

PARTS DRAWING-7

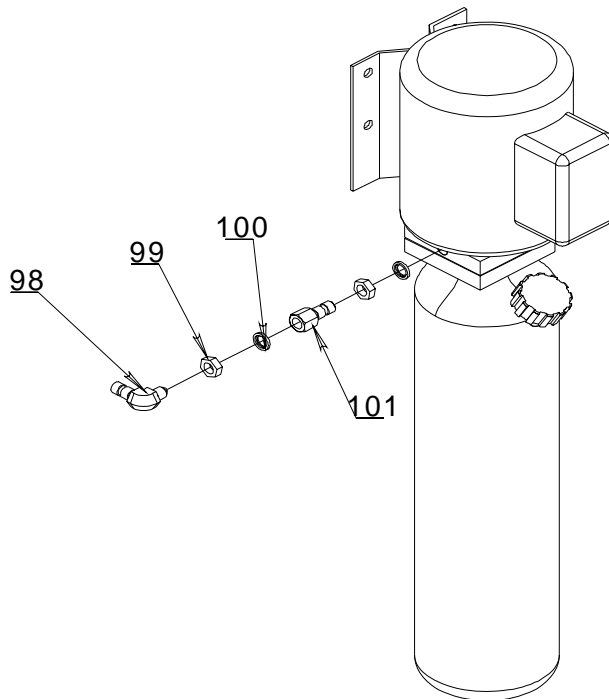
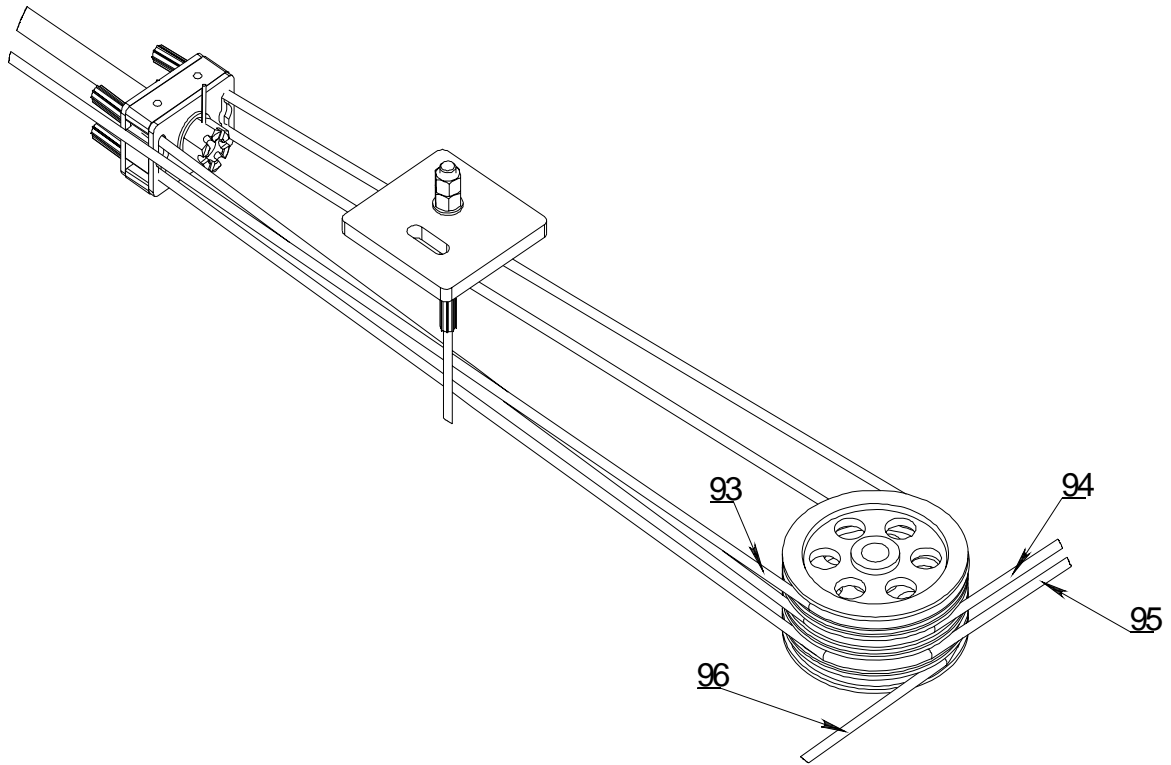

PARTS LIST

ITEM	FACTORY CODE	DESCRIPTION	QTY	NOTE	
1	TT5D-400-01-00	pull blade	2	weld assembly	
2	TT5D-400-02	idler wheel	4	nylon	
3	D16_GB894.1	snap spring	20		D16
4	TT5D-100-05	spindle I	5		
5	M12x35_GB70	Inner hexangular bolt	8		M12
6	D20_GB95	flat washer	14	steel	D20
7	TT5D-200-01B-00	Column II	1	weld assembly	
8	TT5D-200-01A-00	Column I	1	weld assembly	
9	TT5D-200-02-00	safety block I	2	weld assembly	
10	M10x35_GB5781	hexangular bolt	4		M10X35
11	D20_GB96	big washer	2	steel	D20
12	M20_GB41	hexangular nut	14		M20
13	TT5D-300-01B-00	ColumnIV	1	weld assembly	
14	TT5D-300-02-00	safety block II	2	weld assembly	
15	TT5D-300-01A-00	ColumnIII	1	weld assembly	
16		hydraulic pump	1		
17	M8x25_GB5781	hexangular bolt	4		M8X25
18	D8_GB93	spring washer	4		D8
19	D8_GB95	flat washer	12	steel	D8
20		Control box	1		
21	M6x20_GB5781	hexangular bolt	4		M6X20
22	D6_GB95	flat washer	84	steel	D6
23	D6_GB93	spring washer	4		D6
24	M6X16_GB818	Cross screw	4		M6X16
25	M6_GB41	hexangular nut	12		M6
26	QYS-100-02-07	motor base	1		
27	TT5D-100-16-00	Limited stand	2	weld assembly	
28	TT5D-100-01-00	tressel1	4	weld assembly	
29	TT5D-100-02-00	tressel2	4	weld assembly	
30	TT5DL-100-04A/04B-00	Runway1/2	1each	weld assembly	
31	TT5D-100-03-00	Cover	2	weld assembly	
32	SGM-803-16-01	raw pin	4		
33	M6x10_GB818	cover plate	36		M6X10
34	M6x10_GB70	Inner hexangular bolt	65		M6*10
35	TT5D-100-10-01	inner washer	62		
36	TT5D-100-10-03	steel ball	992	steel	
37	TT5D-100-10-02	spring pad	62		
38	TT5D-100-07	hose tie rack	3		
39	TT5D-100-09	cover I	9	nylon	
40	TT5.5F4-300-17	wheel4	11	nodular cast iron	
41	FB090-3025	multiple bush	11		
42	TT5D-100-13	spindle II	3		

ITEM	FACTORY CODE	DESCRIPTION	QTY	NOTE	
43	SGM-802-08	locking plate	8		
44	TT5D-100-12	cover II	1	round steel	
45	D30_GB894.1	snap spring	1		
46	TT5D-100-06-02	cylinder pin	1		
47	M27_GB6179	hexagon slotted nuts	1	steel	
48	D30_GB95	flat washer	3		D30
49	TT5D-100-06-03	clip1	2		
50	TT5D-100-06-04	clip2	1		
51	D5X80_GB91	snap ring	1		D5X80
52	TT5D-100-06-01	cylinder	1		
53	TT5D-500-01-00	cross beam I	1	weld assembly	
54	TT5.5F4-200-01-10	cover2	4	nylon	
55	TT5.5F4-200-01-07	cover1	4	nylon	
56	TT5D-500-03-01A-00	safety A	1	weld assembly	
57	TT5.5F4-200-01-02	spindle2	10		
58	SGM-804-14	compression spring	8		
59	SGM-804-07	pull handle	4	steel plate	
60	TT5D-500-03-03	cylinder cover	4		
61	sns-02-00	safety cylinder	4		
62	SGM-804-04	tie rod spring	8		
63	D2x35_GB91	snap ring	4	carbon steel	D2X35
64	D10_GB894.1	snap spring	4		D10
65	D25_GB894.1	snap spring	8		D25
66	D2x40_GB91	snap ring	8	carbon steel	D2X40
67	M8_GB41	hexangular nut	22		M8
68	TT5D-500-02-01A-00	safety with cable steel A	1	weld assembly	
69	TT5.5F4-200-01-19	safety idler wheel	4		
70	TT5D-500-04	spindleIV	4		
71	TT5.5F4-200-01-05	spindle4	2		
72	TT5.5F4-200-01-03	spindle3	8		
73	D24_GB894.1	snap spring	8		D24
74	M6X40_GB70.1	Inner hexangular bolt	4		M6X40
75	TT5.5F4-200-01-04	nylon sliders	6	nylon	
76	TT5D-500-09	protective motherboard I	4		
77	TT5D-500-02-01B-00	safety with cable steel B	1	weld assembly	
78	TT5D-500-03-01B-00	safety B	1	weld assembly	
79	TT5D-600-07	Carriage block II	4	nylon	
80	TT5D-600-03-01	pulley	8		
81	TT5D-600-05	cover V	8	nylon	
82	TT5D-600-01-05	spindleVIII	2		
83	TT5D-600-01-04	spindleVII	2		
84	TT5D-600-01-06	Steel cable plate	2		

